

**STAGE TECHNOLOGY. SIMPLY. BETTER.**



# ERGO FLEX MUTANT

**PLATFORM WITH PLUG-IN LEGS**

## PLATFORM WITH PLUG-IN LEGS



This platform system features a smooth frame profile with additional multi-functional corner elements.



### Hollow aluminium frames

Smooth frames – shiny look!

2 cm crosspiece for attaching Velcro tape



### The corner

The closed, impact-resistant 90° corner allows the platforms to be connected via the outer groove channel despite the smooth frame.



### Groove channel

The inner groove channel makes it possible to connect the platforms using clamps or connecting hooks and makes this platform compatible with a wide range of platform systems.

The outer groove channel in the corner makes it possible to connect the platforms using clamp connectors.



### Leg mount

The 2M leg mount made of die-cast zinc is designed for use with round pipe or square pipe with dimensions of 40 mm to 60 mm.

The leg can be compacted using an M10 adjustment screw or via an eccentric quick release system depending on the customer's wishes. It is possible to switch between these configurations in seconds.



### Surfaces

A non-slip phenolic plywood (birch throughout) made with waterproof glue or a 22-mm multiplex plywood are available as standard base boards.

Additional surfaces such as carpet, plexiglass etc. are also available upon request, expanding our product portfolio further.



## DETAILS

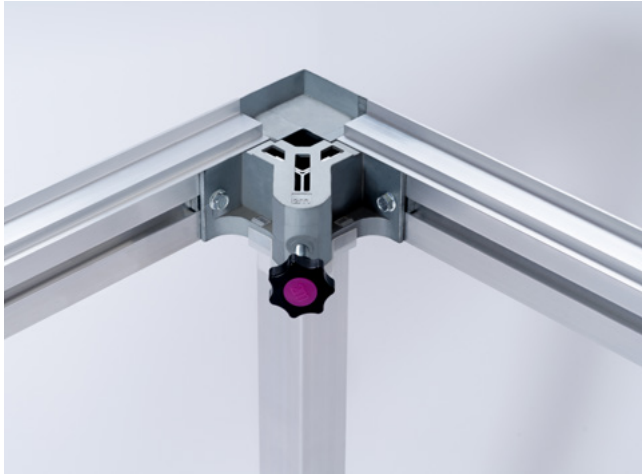

Corner section incl. leg mount without base board



Corner incl. multi-functional groove channel for various connection options

## TECHNICAL DATA



<b>Product category</b>	Platforms with plug-in legs
<b>Movable/Stationary</b>	movable
<b>Dimensions</b>	2 m x 1 m
<b>Special size possible</b>	yes
<b>Weight</b>	45 kg
<b>Backing plate thickness</b>	22 mm
<b>Frame height</b>	90 mm
<b>Pit depth</b>	-
<b>Horizontal test load</b>	1/10 of the vertical test load
<b>Vertical test load</b>	8.5 kN/m <sup>2</sup> (867 kg/m <sup>2</sup> )
<b>Horizontal traffic load</b>	1/10 of the vertical traffic load
<b>Vertical traffic load</b>	5.0 kN/m <sup>2</sup> (510 kg/m <sup>2</sup> )
<b>Max. stage height</b>	-
<b>TÜV certificate</b>	DIN 13814, 4112, 1055, 15921



# ERGO flex mutant



## ACCESSORIES



**Stairs and handrails**



**Railing**



**Feet**

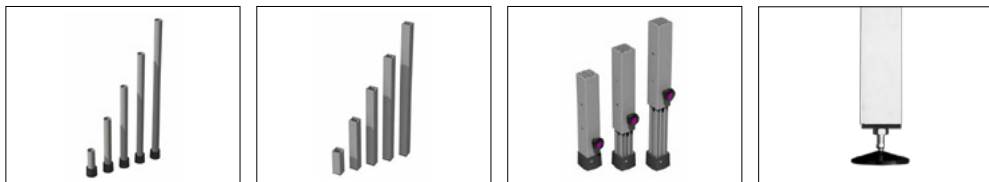

**Connectors**

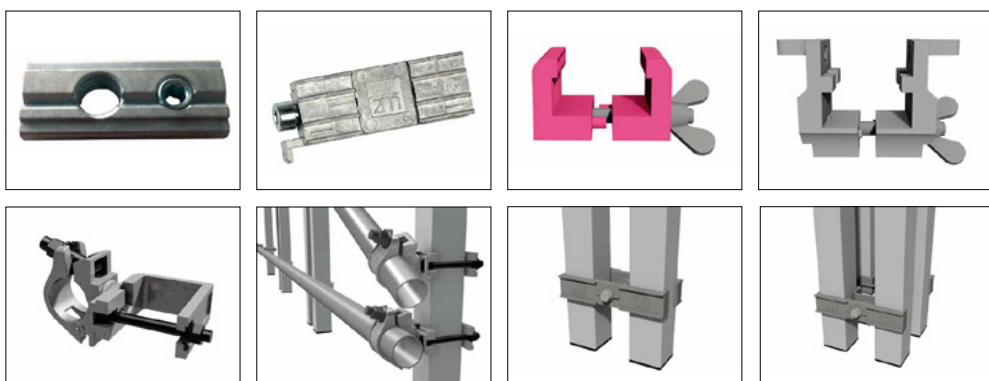

**Transport**



**Facing**

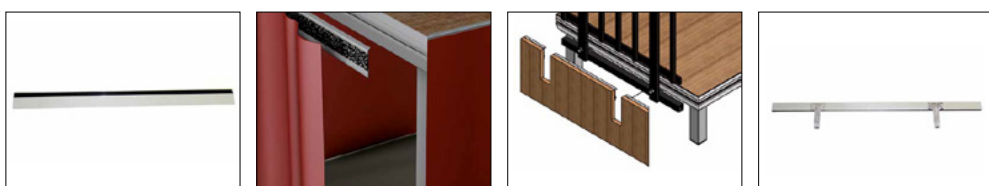

**WORKING TOGETHER  
TO GET THE BEST RESULTS  
WITH YOUR VISION  
AND OUR PASSION.**

**References:**

**[2M-DEUTSCHLAND.DE/EN/REFERENCES](https://2m-deutschland.de/en/references)**



**ENQUIRE NOW!**



**Andre Nölle**  
Sales Manager

→ 02102/13399-13  
→ [info@2m-deutschland.de](mailto:info@2m-deutschland.de)



**Gerrit Pape**  
Project Manager

→ 02102/13399-14  
→ [info@2m-deutschland.de](mailto:info@2m-deutschland.de)